



DEPARTMENT OF THE ARMY

THE INSTITUTE OF HERALDRY
9325 GUNSTON ROAD, ROOM S113
FORT BELVOIR, VIRGINIA 22060-5579

SAAA-IHS

22 November 2019

MEMORANDUM FOR Commander, U.S. Army Financial Management Command,
ATTN: XXXXXXXXXXX, 8899 East 56th Street, Indianapolis, IN 46249

SUBJECT: Authorized Insignia for the U.S. Army Financial Management Command

1. As a result of the reassignment of the U.S. Army Financial Management Command (USAFMCOM) as a major subordinate command of Army Materiel Command (AMC), the following heraldic items are authorized effective 4 October 2019:

- a. Distinctive unit insignia IAW TIOH drawing D-5780(X).
- b. Distinguishing colors IAW TIOH drawing 5-1-674.

2. The shoulder sleeve insignia (TIOH drawing A-1-1125) originally approved for USAFMCOM is cancelled effective 4 October 2019. As outlined within the enclosed DAPE-HR memo, all AMC subordinate units will wear the AMC SSI.

3. The U.S. Army Tank-Automotive and Armaments Command is responsible for the procurement of flags. To obtain your flag, complete DD Form 1348-6 online at www.heraldry.army.mil; citing TIOH Drawing No. 5-1-674, in the remarks section. POC at the Clothing and Heraldry Office is Ms. Franklin, DSN 444-2515 or COMM (215) 737-2515.

4. This authorization is in accordance with AR 670-1, AR 840-10 and DAGO 2019-35, dated 4 October 2019. A copy of this letter will become part of your permanent organizational history files.

5. Your point of contact for this action is Mr. Garrison at keith.a.garrison6.civ@mail.mil or 571-515-0324.

MUGNO.CHARL MUGNO.CHARLES.V.10
20723374
ES.V.1020723374 2019.11.22 10:31:51
-05'00'

Encls

CHARLES V. MUGNO
Director

GENERAL ORDERS

NO. 2019–35



HEADQUARTERS
DEPARTMENT OF THE ARMY
WASHINGTON, DC, 4 October 2019

**REASSIGNMENT OF THE UNITED STATES ARMY FINANCIAL MANAGEMENT COMMAND AS A MAJOR
SUBORDINATE COMMAND OF UNITED STATES ARMY MATERIEL COMMAND**

1. Effective 1 October 2019, United States Army Financial Management Command (USAFMCOM) (Unit Identification Code (UIC): W0NRAA) and its authorities, responsibilities, personnel, and resources (including funding and equipment) is discontinued as a direct reporting unit to the Assistant Secretary of the Army (Financial Management and Comptroller) (ASA (FM&C)) (UIC: W00GAA) and is reassigned as a major subordinate command of United States Army Materiel Command (AMC) (UIC: W0GWAA).
2. The Commanding General, AMC will exercise all authority, direction, and command and control over USAFMCOM. A future Headquarters, Department of the Army execution order will include detailed guidance on missions, functions, and responsibilities.
3. USAFMCOM will continue to provide direct support to the Office of the ASA (FM&C) in executing its statutory responsibilities and is authorized direct liaison authority with the ASA (FM&C) and other strategic partners to ensure accomplishment of those tasks.
4. USAFMCOM will continue to provide functional oversight of finance and comptroller tactical formations to ensure technical readiness.

[SASA]

Ryan D. McCarthy
Secretary of the Army

DISTRIBUTION: This publication is available in electronic media only and is intended for the Regular Army, the Army National Guard/Army National Guard of the United States, and the U.S. Army Reserve.

* This Department of the Army General Orders supersedes 2017–08, dated 17 January 2017.



**US ARMY FINANCIAL MANAGEMENT
COMMAND**

(LEFT-HAND SIDE)

****This Drawing is 6X Actual size****

ACTUAL SIZE-----1 1/8" ± 1/64" Wide
(2.86cm ± .040cm)

METAL COLOR & PLATING-----Gold

FINISH-----Mirror-like polish

DESIGN:

CHARGES-----Flush, details to be incised; eagle to be recessed and modeled.

LETTERING-----Epoxy Blue #20

PIERCING-----None

EPOXY-----Stoning

CHIP Nos-----Blue #20

D-5780 TYPE III

For Color Placement Only
Not For Color Match

APPROVED
THE INSTITUTE OF HERALDRY,
DEPARTMENT OF THE ARMY

Charles V. Mugno

CHARLES V. MUGNO
DIRECTOR



**US ARMY FINANCIAL MANAGEMENT
COMMAND**

(LEFT-HAND SIDE)

D-5780 TYPE III

****This Drawing is 6X Actual size****

ACTUAL SIZE-----1 1/8" ± 1/64" Wide
(2.86cm ± .040cm)

METAL COLOR & PLATING-----Gold

FINISH-----Mirror-like polish

DESIGN:

CHARGES-----Flush, details to be incised; eagle to be recessed and modeled.

APPROVED
THE INSTITUTE OF HERALDRY,
DEPARTMENT OF THE ARMY

LETTERING-----Epoxy Blue #20

PIERCING-----None

EPOXY-----Stoning

CHIP Nos-----Blue #20

CHARLES V. MUGNO
DIRECTOR



20
all shaded areas

**US ARMY FINANCIAL MANAGEMENT
COMMAND**

(LEFT-HAND SIDE)

D-5780 TYPE III

****This Drawing is 6X Actual size****

ACTUAL SIZE-----1 1/8" ± 1/64" Wide
(2.86cm ± .040cm)

METAL COLOR & PLATING-----Gold

FINISH-----Mirror-like polish

DESIGN:

CHARGES-----Flush, details to be incised; eagle to be recessed and modeled.

APPROVED
THE INSTITUTE OF HERALDRY,
DEPARTMENT OF THE ARMY

LETTERING-----Epoxy Blue #20

PIERCING-----None

EPOXY-----Stoning

CHIP Nos-----Blue #20

CHARLES V. MUGNO
DIRECTOR



**US ARMY FINANCIAL MANAGEMENT
COMMAND**

(RIGHT-HAND SIDE)

****This Drawing is 6X Actual size****

ACTUAL SIZE-----1 1/8" ± 1/64" Wide
(2.86cm ± .040cm)

METAL COLOR & PLATING-----Gold

FINISH-----Mirror-like polish

DESIGN:

CHARGES-----Flush, details to be incised; eagle to be recessed and modeled.

LETTERING-----Epoxy Blue #20

PIERCING-----None

EPOXY-----Stoning

CHIP Nos-----Blue #20

D-5780X TYPE III

For Color Placement Only
Not For Color Match

APPROVED
THE INSTITUTE OF HERALDRY,
DEPARTMENT OF THE ARMY

CHARLES V. MUGNO
DIRECTOR



**US ARMY FINANCIAL MANAGEMENT
COMMAND**

(RIGHT-HAND SIDE)

D-5780X TYPE III

****This Drawing is 6X Actual size****

ACTUAL SIZE-----1 1/8" ± 1/64" Wide
(2.86cm ± .040cm)

METAL COLOR & PLATING-----Gold

FINISH-----Mirror-like polish

DESIGN:

CHARGES-----Flush, details to be incised; eagle to be recessed and modeled.

APPROVED
THE INSTITUTE OF HERALDRY,
DEPARTMENT OF THE ARMY

LETTERING-----Epoxy Blue #20

PIERCING-----None

EPOXY-----Stoning

CHIP Nos-----Blue #20

CHARLES V. MUGNO
DIRECTOR



20
all shaded areas

**US ARMY FINANCIAL MANAGEMENT
COMMAND**
(RIGHT-HAND SIDE)

D-5780X TYPE III

****This Drawing is 6X Actual size****

- ACTUAL SIZE-----1 1/8" ± 1/64" Wide
(2.86cm ± .040cm)
- METAL COLOR & PLATING-----Gold
- FINISH-----Mirror-like polish
- DESIGN:
- CHARGES-----Flush, details to be incised; eagle to be recessed and modeled.
- LETTERING-----Epoxy Blue #20
- PIERCING-----None
- EPOXY-----Stoning
- CHIP Nos-----Blue #20

APPROVED
THE INSTITUTE OF HERALDRY,
DEPARTMENT OF THE ARMY

Charles V. Mugno
CHARLES V. MUGNO
DIRECTOR

8 7 6 5 4 3 2 1

| REVISIONS | | | |
|-----------|-------------|------|----------|
| ZONE/LTR | DESCRIPTION | DATE | APPROVED |
| | | | |

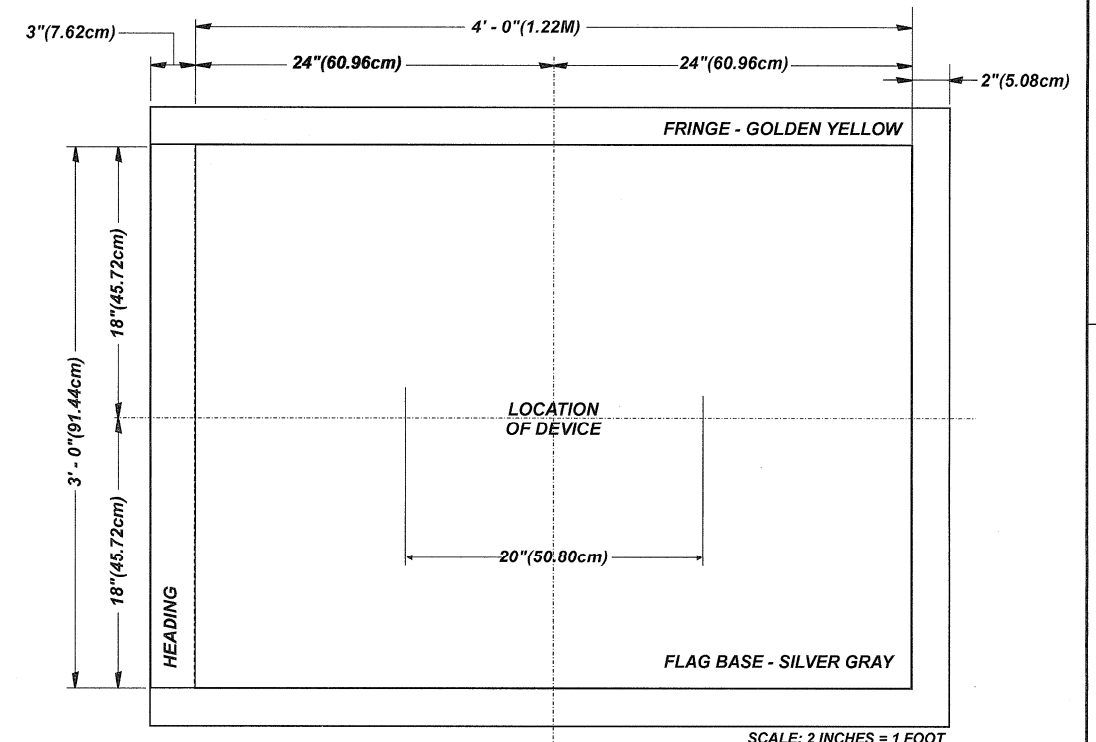
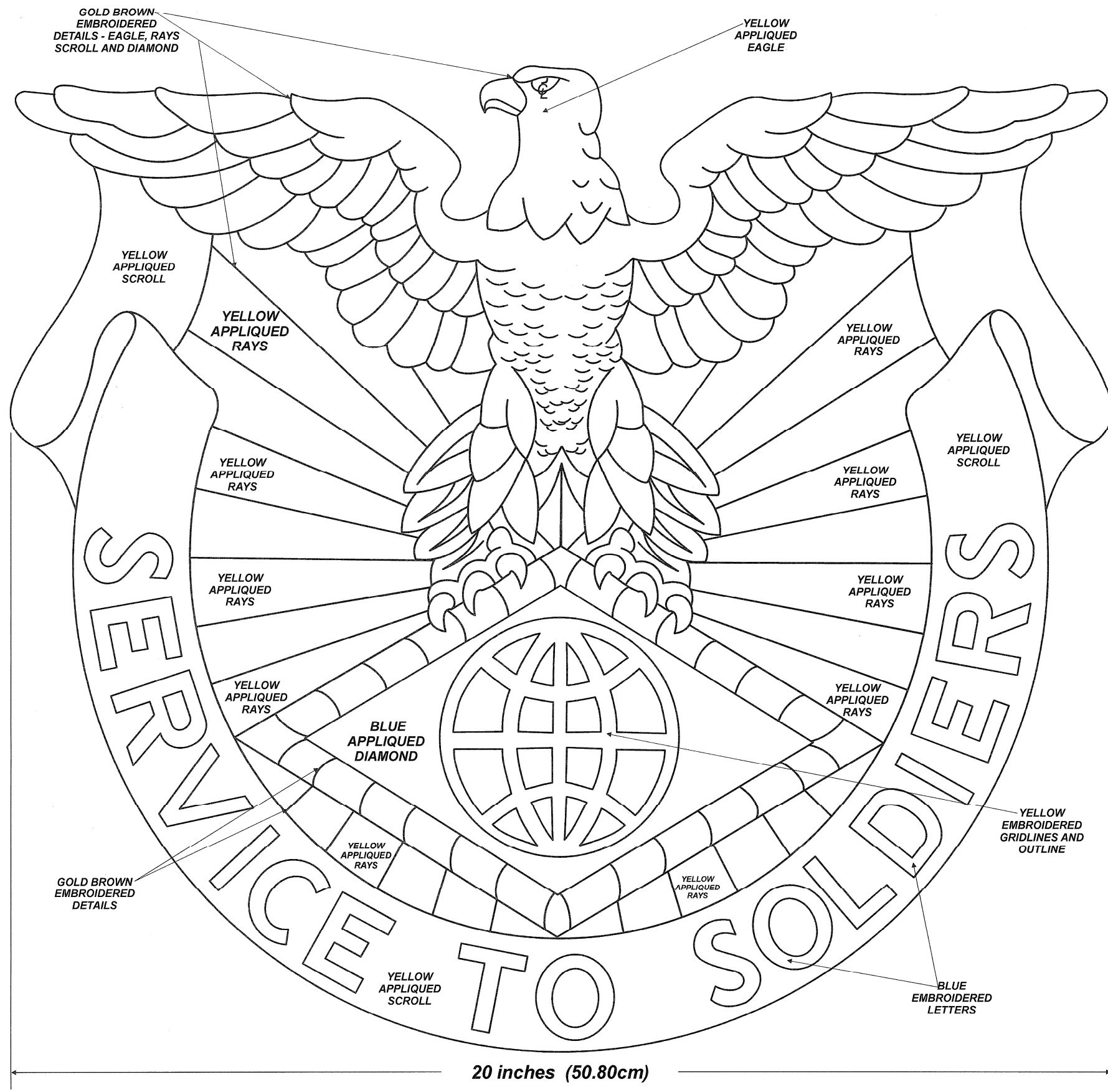

- NOTES:**
1. TO BE MANUFACTURED IN ACCORDANCE WITH LATEST REVISION OF SPECIFICATION MIL-DTL-2692.
 2. DEVICE SHALL APPEAR ON BOTH SIDES OF THE FLAG AND WILL APPEAR AS ILLUSTRATED ON BOTH SIDES.
 3. EAGLE, DIAMOND, GLOBE, BACKGROUND AND SCROLL TO BE APPLIQUE. OUTLINES, DETAILS AND LETTERS TO BE EMBROIDERY.
 4. FOR HEADING SEE TIOH DWG No. 5-1-45E.
 5. ALL DIMENSIONS ARE EXCLUSIVE OF HEMS.
 6. DEVICE TO BE APPLIED TO FLAG BASE WITH GOLD BROWN EMBROIDERY (CABLE No. 67194).

MATERIALS:

| | |
|-----------|-------------------------------|
| FLAG BASE | RAYON BANNER CLOTH |
| FRINGE | RAYON, 2-1/2" WIDTH |
| DEVICE | RAYON APPLIQUE AND EMBROIDERY |

| CABLE NUMBERS OF COLORS | CLOTH | YARN |
|-------------------------|--------------------|-------|
| FLAG BASE | SILVER GRAY | 65008 |
| FRINGE | GOLDEN YELLOW | 67104 |
| DEVICE | YELLOW | 65002 |
| | NATIONAL FLAG BLUE | 80077 |
| | GOLD BROWN | 67124 |
| | | 67194 |

SUPERSEDES TIOH DWG. No. 5-1-674 DTD. 18 APRIL 1986
FORMERLY U.S. ARMY FINANCE COMMAND

| | | |
|---|--|-------------------------------|
| UNLESS OTHERWISE SPECIFIED DIMENSIONS ARE IN INCHES TOLERANCES ON FRACTIONS DECIMALS ANGLES | THE INSTITUTE OF HERALDRY, DEPARTMENT OF THE ARMY 9325 GUNSTON RD S-113 FORT BELVOIR, VA 22060-5579 | |
| | DEVICE FOR FLAG U. S. ARMY FINANCIAL MANAGEMENT COMMAND | |
| MATERIAL: | EXAMINED <i>sa</i> | SIZE CODE IDENT. NO |
| | CHECKED <i>ca</i> | D 22571 |
| | PREPARED <i>ca</i> | 5-1-674 |
| | APPROVED <i>Charles V. Mugno</i> CHARLES V. MUGNO DIRECTOR | SCALE FULL DATE 7 AUGUST 2015 |



DEPARTMENT OF THE ARMY
OFFICE OF THE DEPUTY CHIEF OF STAFF G-1
300 ARMY PENTAGON
WASHINGTON, DC 20310-0300

21 FEB 2010

DAPE-HR

MEMORANDUM FOR Commanding General, Headquarters, United States Army
Materiel Command (AMC), 9301 Capek Road, Fort Belvoir, VA 22060-5527

SUBJECT: Request Withdrawal of the Shoulder Sleeve Insignia (SSI) for AMC
Subordinate Organizations

1. Ma'am, your request is approved and effective immediately based on the justification provided in the basic correspondence.
2. The previously approved SSIs of the subordinate units under AMC are rescinded. The subordinate units under AMC are allowed to retain their current Distinctive Unit Insignia (DUI). The flags of the subordinate units under AMC will be redesigned with their DUI in lieu of their rescinded SSI.
3. All subordinate units activated in the future will wear the AMC SSI with the exception of Surface Deployment and Distribution Command.
4. A copy of this memorandum along with the basic correspondence has been provided to Ms Bonnie Henning, at The Institute of Heraldry to rescind the SSIs and redesign the flags. She can be reached at DSN 656-4972, or by email at bonnie.henning@conus.army.mil.
5. Should you or your staff have questions concerning this action, please contact SGM Katrina Easley, Uniform Policy Branch at DSN 225-5403, commercial (703) 695-5403 or at katrina.easley@hqda.army.mil.

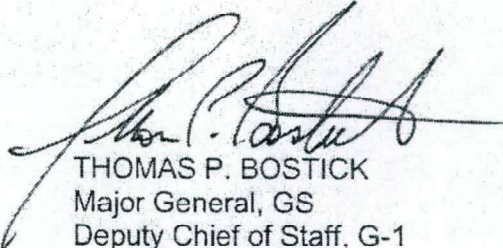
THOMAS P. BOSTICK
Major General, GS
Deputy Chief of Staff, G-1

US ARMY FINANCIAL MANAGEMENT COMMAND



DISTINCTIVE UNIT INSIGNIA

Description. A gold color metal and enamel device 1 1/8 inches (2.86 cm) in height overall consisting of a gold eagle displayed and standing on a dark blue horizontal diamond shaped device edged gold on which is centered a dark blue globe gridlined gold; from the diamond extending outward is a series of rays terminating at a semicircular scroll inscribed "SERVICE TO SOLDIERS" in dark blue letters. This insignia is to be worn in pairs.

Symbolism. Golden yellow (gold), one of the colors of the Finance Corps, signifies the unit's relationship to the Corps. Blue, one of our national colors, is associated with prestige. The eagle, a national emblem featured on some of our coins and paper currency, is symbolic of the unit's swift performance of its mission. The diamond shape is adapted from the branch insignia of the Finance Corps. The globe alludes to its worldwide services as do the rays extending to all points of the compass. The rays also refer to the numerous services provided by the unit to the soldier.

Background. The distinctive unit insignia was originally approved for the U.S. Army Finance and Accounting Center on 1 November 1985. It was redesignated for the U.S. Army Finance Command on 8 March 1996. The insignia was redesignated for the U.S. Army Financial Management Command effective 1 May 2010.

US ARMY FINANCIAL MANAGEMENT COMMAND



FLAG

Background. All subordinate units of AMC are authorized a flag with branch based colored background and DUI centered. (TIOH Drawing 5-1-0674).

FOR SUBDUED INSIGNIA

OCP:
 BLUE AREAS TO BE BAGBY GREEN 67204.
 YELLOW AREAS TO BE BLACK 67138.

REVISIONS

SUPERSEDES TIOH DWG. No. A-1-1125 DTD. 30 JANUARY 2018

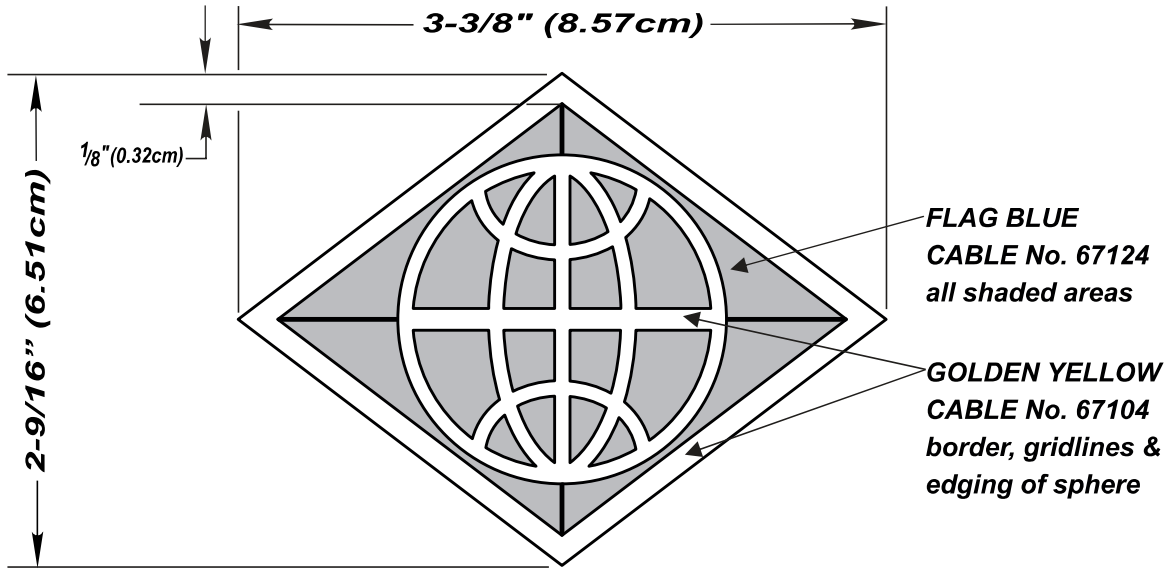

DESIGNED FOR OVEREDGE STITCHING

STITCH COUNT
STITCHES 5859 (MINIMUM)
DENIER 90/2
SPAN 12/4

| | | |
|----------|---|------------|
| EXAMINED | <i>TLO</i> | |
| CHECKED | <i>CA</i> | <i>SAD</i> |
| PREPARED | CAIford | |
| APPROVED |  CHARLES V. MUGNO DIRECTOR | |

THE INSTITUTE OF HERALDRY, DEPARTMENT OF THE ARMY
 9325 GUNSTON RD, RM S-113 FORT BELVOIR, VA 22060-5579

SHOULDER SLEEVE INSIGNIA
U. S. ARMY FINANCIAL
MANAGEMENT COMMAND

| | | |
|----------|-------------------|---------------------|
| SIZE | CONTROL IDENT. NO | A - 1 - 1125 |
| A | 22571 | |

MATERIALS: TO BE MANUFACTURED IN ACCORDANCE WITH MIL-DTL-14652 SCALE FULL DATE **10 OCTOBER 2018**

CANCELLED 4 OCTOBER 2019